

LHT UNV 2482 UNIVERSAL HEADLIGHT KIT

Wiring Instructions

Start by mounting the head lights to your cart, in the location of your choice A 5/16" drill will be required. Next, attach the 2 pin connectors of the short wire harness to each of the head lights. Now attach the main wire harness to one of the extra headlight connectors.

Route the harness down the left hand side (driver's side) of the cart.

Now locate the two white wires with a 1/4 female tab connector. Route these two wires to the location you chose for your light switch. Connect them to the light switch supplied and install the switch into a 1/2" hole after drilling.

Route the remaining length of harness under your cart and into the battery area. Use the battery diagrams supplied below to determine the best attachment points for the battery connections. Remember that the fused White lead will connect to 12 volt battery positive and the black lead will connect to 12 volt battery negative. NEVER CONNECT A GROUND TO THE CHASSIS OF AN ELECTRIC CART! To complete the installation, use the wire tie straps included in the kit to secure the wiring to the chassis.

On 48 volt carts using 8 volt batteries, a voltage reducer or 48 volt bulbs should be used. 48 volt bulbs are available separately (not included in this kit) through *Buggies Unlimited*. On 36 volt carts you can also use 36 volt bulbs and no reducer is required or you can simply use two 6 volt batteries for twelve volts as shown on page 2.

Headlight Wiring For 48 Volt Electric Carts

Front of Cart for all gures. ↑

(Fig. A) Club Car DS Model 48-Volt Battery Pack

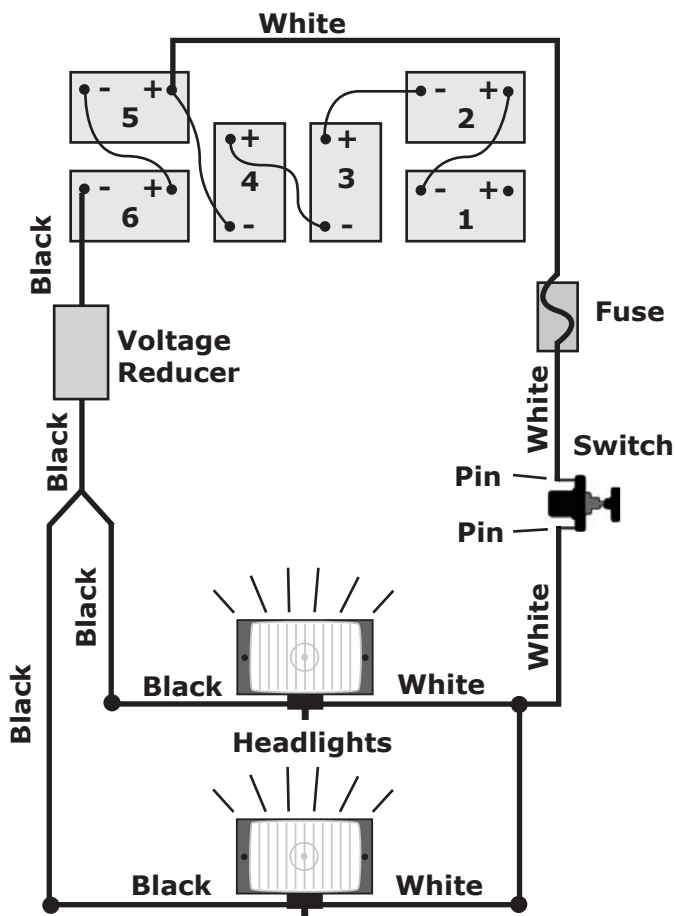

(Fig. B) Yamaha 48-Volt Battery Pack

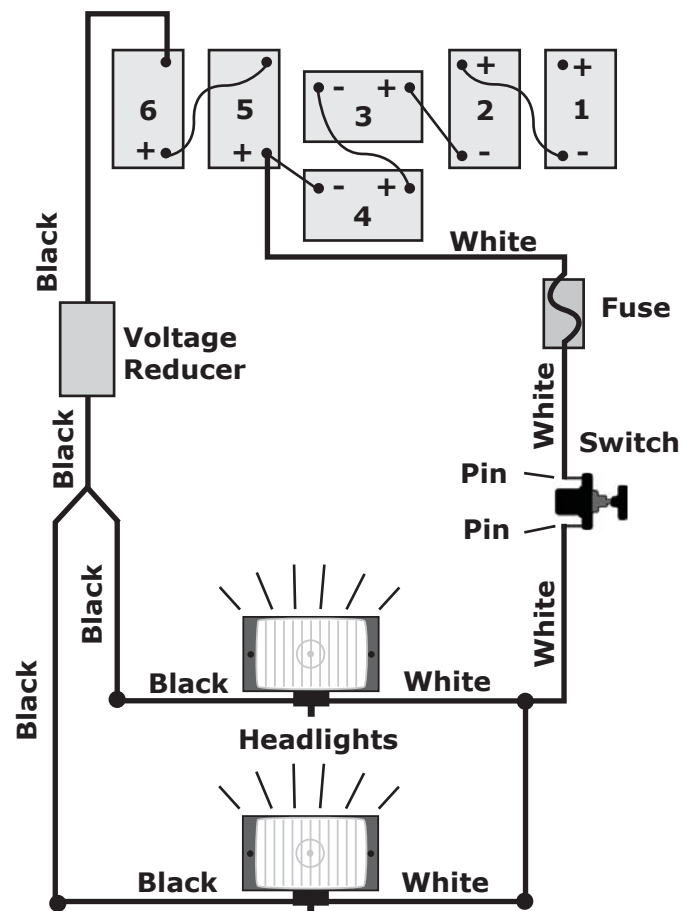

Headlight Wiring For 36 Volt Electric Carts

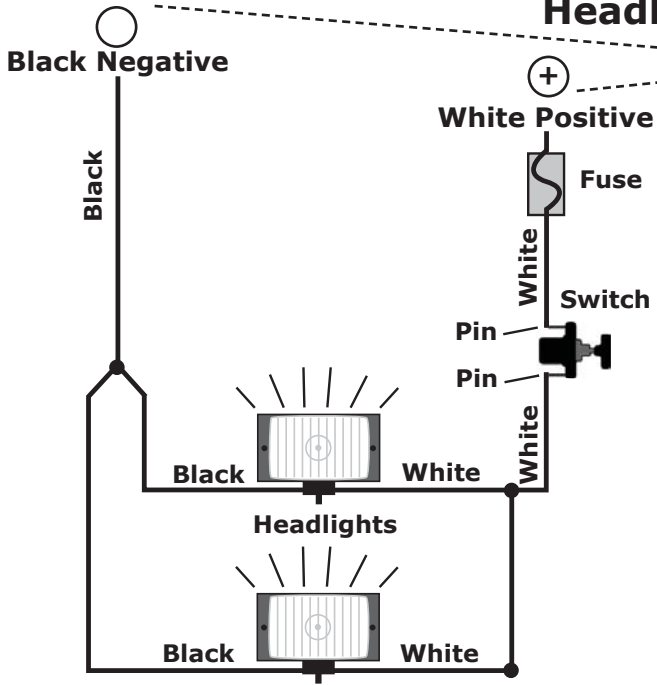

To see which battery to connect these to, please see Figure C, D, E, F or G to find the diagram that corresponds with your make and model of cart.

Front of Cart for all figures.

(Fig. C) Club Car Precedent Model 48-Volt Battery Pack

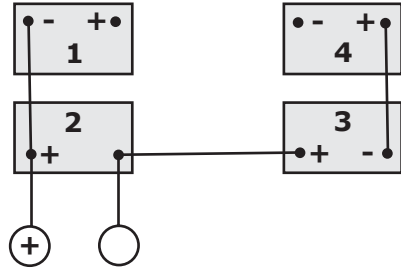

(Fig. D) EZGO TXT Model 36-Volt Battery Pack

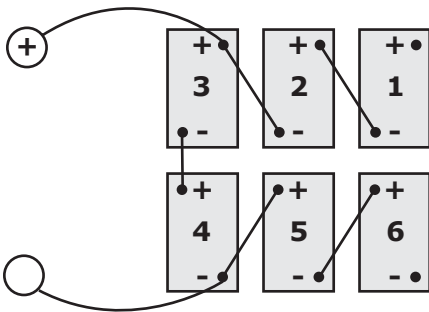

(Fig. E) EZGO Marathon Model 36-Volt Battery Pack

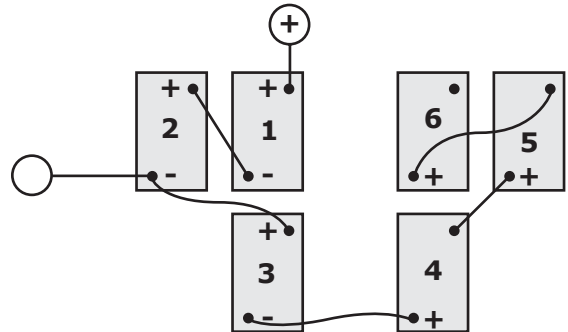

(Fig. F) Club Car DS Model 36-Volt Battery Pack

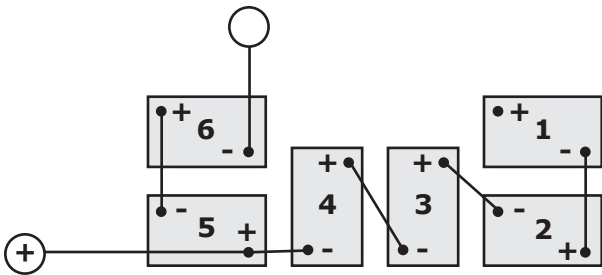

(Fig. G) Yamaha 36-Volt Battery Pack

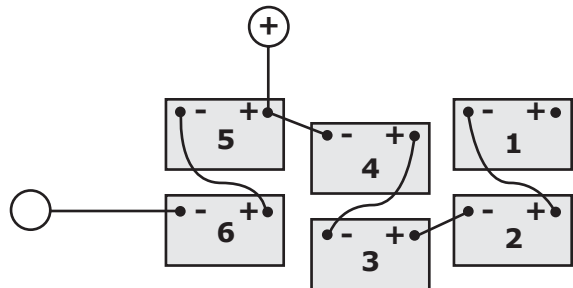

Headlight Wiring For 12 Volt Gas Carts

